

• General Description

The ZMS038N10N combines advanced trench MOSFET technology with a low resistance package to provide extremely low $R_{DS(ON)}$.

• Features

- Advance high cell density Trench technology
- Low $R_{DS(ON)}$ to minimize conductive loss
- Low Gate Charge for fast switching
- Low Thermal resistance

• Application

- Synchronous Rectification for AC-DC/DC-DC converter
- Oring switches
- Power Tools

• Ordering Information:

Part NO.	ZMS038N10N
Marking	ZMS038N10
Packing Information	REEL TAPE
Basic ordering unit (pcs)	3000

• Absolute Maximum Ratings (T_C =25°C)

Parameter	Symbol	Rating	Unit
Drain-Source Voltage	V_{DS}	100	V
Gate-Source Voltage	V_{GS}	±20	V
Continuous Drain Current(TC=25°C)	$I_{D@TC=25°C}$	100	A
	$I_{D@TC=75°C}$	76	A
	$I_{D@TC=100°C}$	63	A
Pulsed Drain Current ①	I_{DM}	260	A
Total Power Dissipation(TC=25°C)	$P_D@TC=25°C$	150	W
Total Power Dissipation(TA=25°C)	$P_D@TA=25°C$	4	W
Operating Junction Temperature	T_J	-55 to 150	°C
Storage Temperature	T_{STG}	-55 to 150	°C
Single Pulse Avalanche Energy@L=0.1mH	E_{AS}	360	mJ

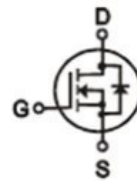
• Product Summary

$V_{DS} = 100V$

$R_{DS(ON)} = 3.8m\Omega$

$I_D = 100A$

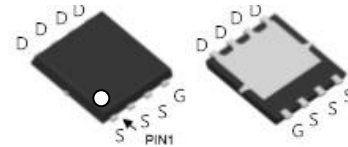

DFN5 x 6

•Thermal resistance

Parameter	Symbol	Min.	Typ.	Max.	Unit
Thermal resistance, junction - case	R _{thJC}	-	-	0.8	° C/W
Thermal resistance, junction - ambient	R _{thJA}	-	-	31	° C/W
Soldering temperature, wave soldering for 10s	T _{sold}	-	-	265	° C

•Electronic Characteristics

Parameter	Symbol	Condition	Min.	Typ	Max.	Unit
Drain-Source Breakdown Voltage	BV _{DSS}	V _{GS} =0V, I _D =250uA	100			V
Gate Threshold Voltage	V _{GS(TH)}	V _{GS} =V _{DS} , I _D =250uA	1.3	1.9	2.5	V
Drain-Source Leakage Current	I _{DSS}	V _{DS} =100V, V _{GS} =0V			1.0	uA
Gate- Source Leakage Current	I _{GSS}	V _{GS} =±20V, V _{DS} =0V			±100	nA
Static Drain-source On Resistance	R _{DS(ON)}	V _{GS} =10V, I _D =25A		3.8	4.5	mΩ
		V _{GS} =4.5V, I _D =15A		4.8	5.5	mΩ
Forward Transconductance	g _{FS}	V _{DS} =25V, I _D =10A		130		s
Source-drain voltage	V _{SD}	I _S =25A		0.8	1.28	V

•Electronic Characteristics

Parameter	Symbol	Condition	Min.	Typ	Max.	Unit
Input capacitance	C _{iss}	V _{GS} =0V, V _{DS} =20V f = 1MHz	-	4800	-	pF
Output capacitance	C _{oss}		-	760	-	
Reverse transfer capacitance	C _{rss}		-	30	-	

•Gate Charge characteristics(T_a = 25°C)

Parameter	Symbol	Condition	Min.	Typ	Max.	Unit
Total gate charge	Q _g	V _{DD} = 30V	-	20	-	nC
Gate - Source charge	Q _{gs}	I _D = 20A	-	11	-	
Gate - Drain charge	Q _{gd}	V _{GS} = 10V	-	10	-	

Note: ① Pulse Test : Pulse width ≤ 300μs, Duty cycle ≤ 2% ;

Fig.1 Gate-Charge Characteristics

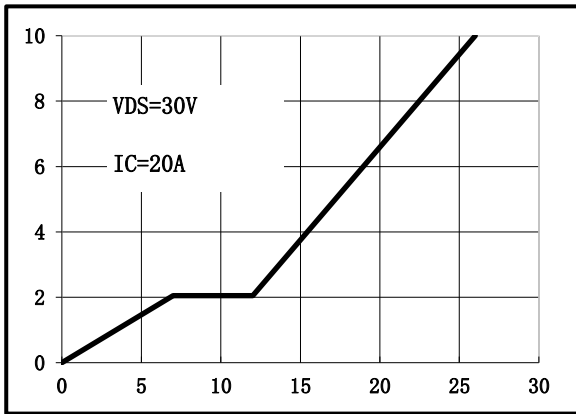

Fig.2 Capacitance Characteristics

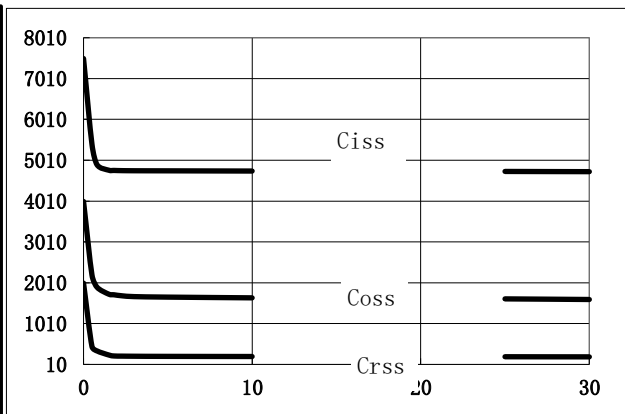

Fig.3 Power Dissipation

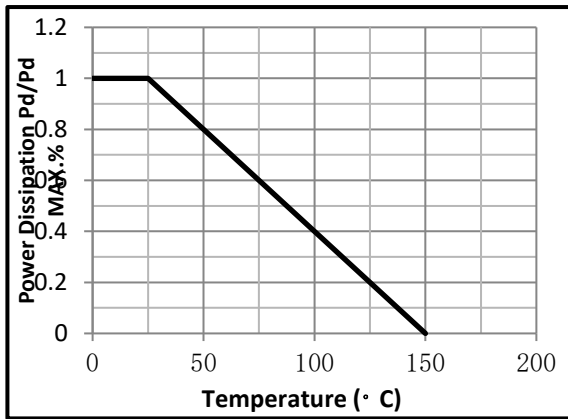

Fig.4 Typical output Characteristics

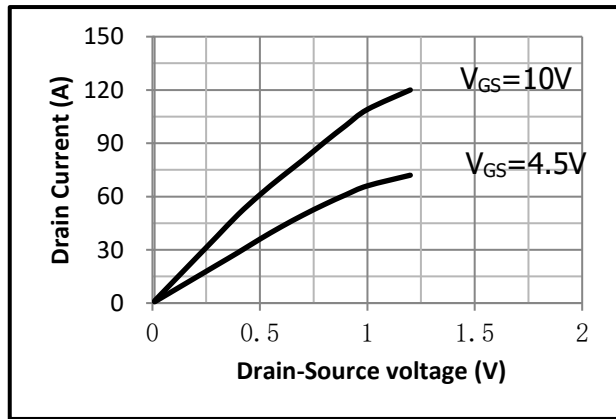

Fig.5 Threshold Voltage V.S Junction Temperature

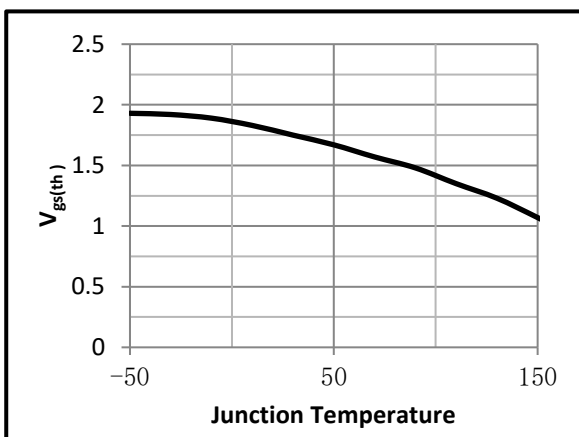

Fig.6 Resistance V.S Drain Current

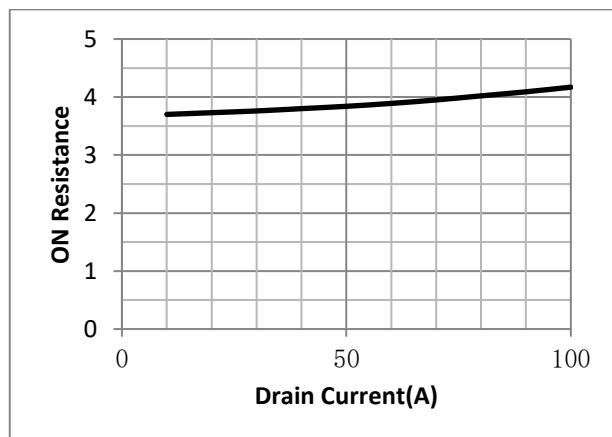

Fig.7 On-Resistance VS Gate Source Voltage

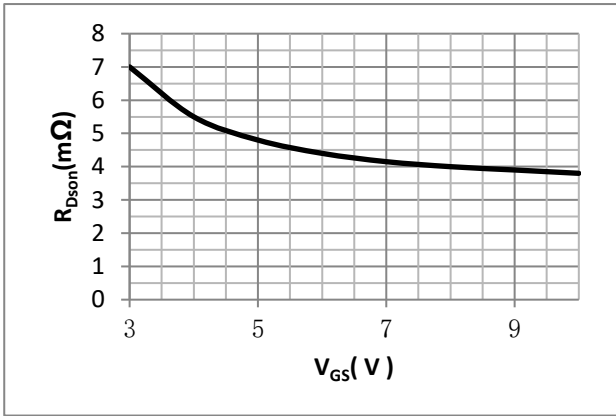

Fig.8 On-Resistance V.S Junction Temperature

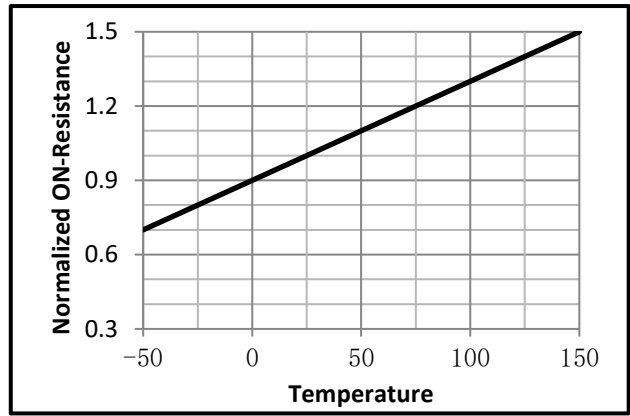

Fig.9 Switching Time Measurement Circuit

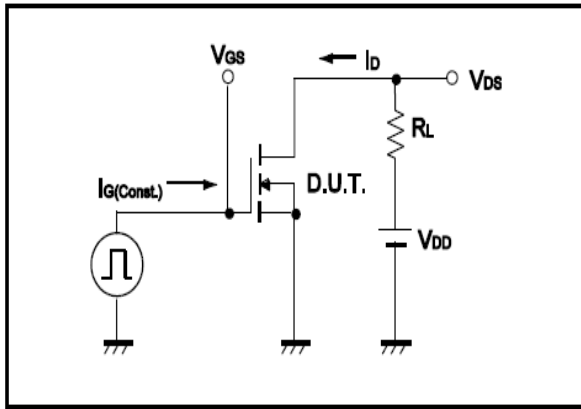

Fig.10 Gate Charge Waveform

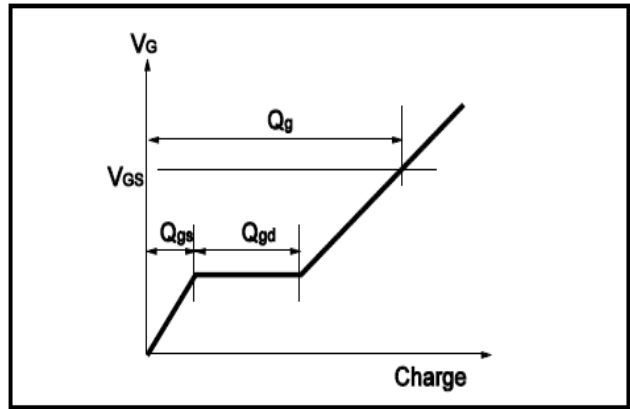

Fig.11 Switching Time Measurement Circuit

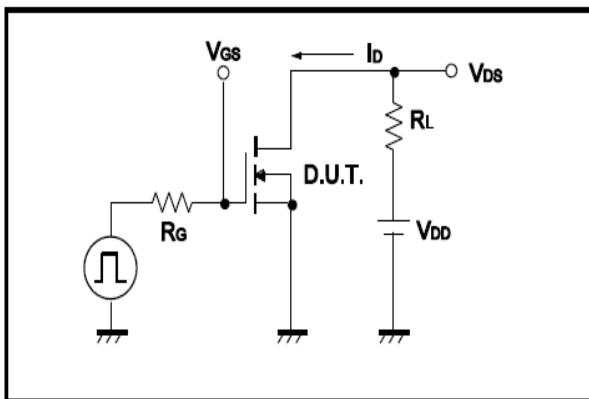

Fig.12 Gate Charge Waveform

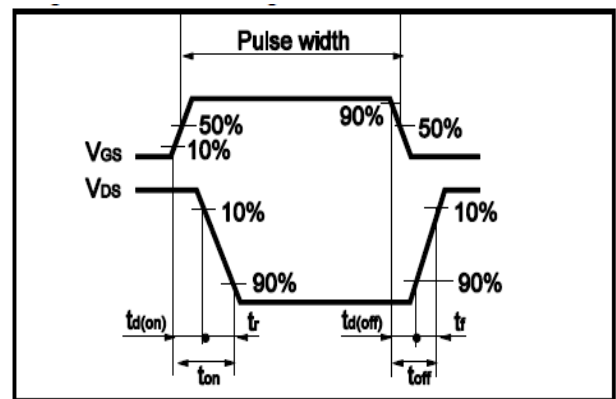

Fig.13 Avalanche Measurement Circuit

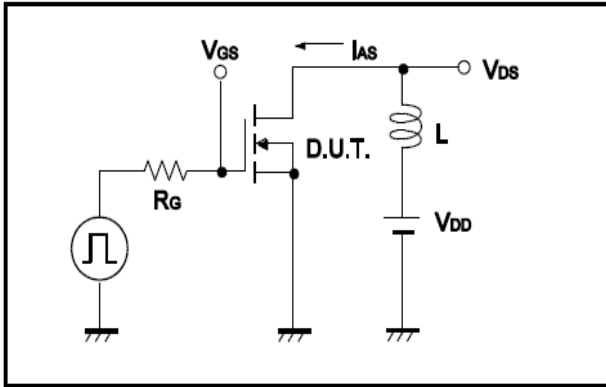
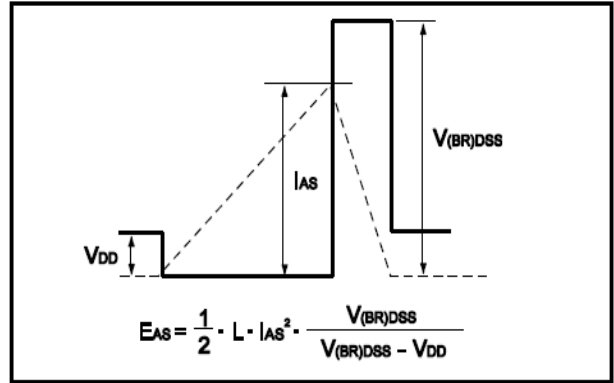

Fig.14 Avalanche Waveform





•Dimensions (DFN5x6)

Unit: mm

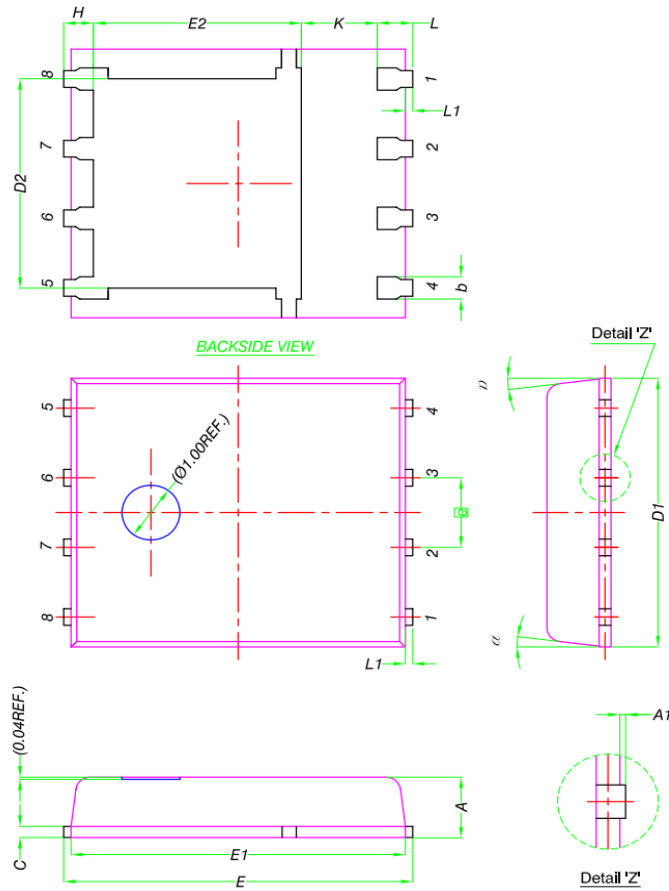

DIM.	MILLIMETERS		
	MIN.	NOM.	MAX.
A	0.90	1.00	1.10
A1	0	-	0.05
b	0.33	0.41	0.51
C	0.20	0.25	0.30
D1	4.80	4.90	5.00
D2	3.61	3.81	3.96
E	5.90	6.00	6.10
E1	5.70	5.75	5.80
E2	3.38	3.58	3.78
e	1.27 BSC		
H	0.41	0.51	0.61
K	1.10	-	-
L	0.51	0.61	0.71
L1	0.06	0.13	0.20
α	0°	-	12°