

### • General Description

The ZMC88405D combines advanced trench MOSFET technology with a low resistance package to provide extremely low  $R_{DS(ON)}$ . It combines one N channel MOSFET and one P channel MOSFET.

### • Features

- Advance high cell density Trench technology
- Low  $R_{DS(ON)}$  to minimize conductive loss
- Low Gate Charge for fast switching
- Dual DIE in one package

### • Application

- Power Management in Notebook Computer
- BLDC Motor driver

### • Ordering Information:

Part NO.	ZMC88405D
Marking	ZMC88405
Packing Information	REEL TAPE
Basic ordering unit (pcs)	2500

### • N Channel Absolute Maximum Ratings ( $T_C = 25^\circ\text{C}$ )

Parameter	Symbol	Rating	Unit
Drain-Source Voltage	$V_{DS}$	40	V
Gate-Source Voltage	$V_{GS}$	20	V
Continuous Drain Current	$I_{D@TC=25^\circ\text{C}}$	28	A
	$I_{D@TC=75^\circ\text{C}}$	19	A
	$I_{D@TC=100^\circ\text{C}}$	15.7	A
Pulsed Drain Current <sup>①</sup>	$I_{DM}$	60	A
Total Power Dissipation( $TC=25^\circ\text{C}$ )	$P_D@TC=25^\circ\text{C}$	50	W
Total Power Dissipation( $TA=25^\circ\text{C}$ )	$P_D@TA=25^\circ\text{C}$	2.0	W
Operating Junction Temperature	$T_J$	-55 to 150	$^\circ\text{C}$
Storage Temperature	$T_{STG}$	-55 to 150	$^\circ\text{C}$
Single Pulse Avalanche Energy	$E_{AS}$	35	mJ

### • Product Summary

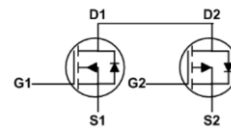

$V_{DS1} = 40\text{V}$   
 $V_{DS2} = -40\text{V}$   
 $R_{DS(ON)1} = 19\text{m}\Omega$   
 $R_{DS(ON)2} = 39\text{m}\Omega$   
 $I_{D1} = 28\text{A}$   
 $I_{D2} = -18\text{A}$



**•P Channel Absolute Maximum Ratings (T<sub>c</sub> =25°C)**

Parameter	Symbol	Rating	Unit
Drain-Source Voltage	V <sub>DS</sub>	-40	V
Gate-Source Voltage	V <sub>GS</sub>	±20	V
Continuous Drain Current	I <sub>D@TC=25°C</sub>	-18	A
	I <sub>D@TC=75°C</sub>	-13.6	A
	I <sub>D@TC=100°C</sub>	-11.3	A
Pulsed Drain Current ④	I <sub>DM</sub>	-36	A
Total Power Dissipation	P <sub>D@TC=25°C</sub>	50	W
Total Power Dissipation	P <sub>D@TA=25°C</sub>	2.0	W
Operating Junction Temperature	T <sub>J</sub>	-55 to 150	°C
Storage Temperature	T <sub>STG</sub>	-55 to 150	°C
Single Pulse Avalanche Energy	E <sub>AS</sub>	35	mJ

**•Thermal resistance**

Parameter	Symbol	Min.	Typ.	Max.	Unit
Thermal resistance, junction - case	R <sub>thJC</sub>	-	-	2.1	° C/W
Thermal resistance, junction - ambient	R <sub>thJA</sub>	-	-	62.5	° C/W
Soldering temperature, wavesoldering for 10s	T <sub>sold</sub>	-	-	265	° C

**•N Channel Electronic Characteristics**

Parameter	Symbol	Condition	Min.	Typ	Max.	Unit
Drain-Source Breakdown Voltage	BV <sub>DSS</sub>	V <sub>GS</sub> =0V, I <sub>D</sub> =250uA	40			V
Gate Threshold Voltage	V <sub>GS(TH)</sub>	V <sub>GS</sub> =V <sub>DS</sub> , I <sub>D</sub> =250uA	1.2	1.6	2.5	V
Drain-Source Leakage Current	I <sub>DSS</sub>	V <sub>DS</sub> =40V, V <sub>GS</sub> =0V			1.0	uA
Gate- Source Leakage Current	I <sub>GSS</sub>	V <sub>GS</sub> =±20V, V <sub>DS</sub> =0V			±100	nA
Static Drain-source On Resistance	R <sub>DS(ON)</sub>	V <sub>GS</sub> =10V, I <sub>D</sub> =6A		19	24	mΩ
		V <sub>GS</sub> =4.5V, I <sub>D</sub> =4A		28	36	mΩ
Forward Transconductance	g <sub>FS</sub>	V <sub>DS</sub> =25V, I <sub>D</sub> =5A		2		s

**•Electronic Characteristics**

Parameter	Symbol	Condition	Min.	Typ	Max.	Unit
Input capacitance	C <sub>iss</sub>	f = 1MHz	-	850	-	pF



Output capacitance	Coss		-	190	-	
Reverse transfer capacitance	Crss		-	100	-	

**•Gate Charge characteristics(T<sub>a</sub> = 25°C)**

Parameter	Symbol	Condition	Min.	Typ	Max.	Unit
Total gate charge	Qg	V <sub>DD</sub> = 25V	-	10	-	nC
Gate - Source charge	Qgs	I <sub>D</sub> = 6A	-	4	-	
Gate - Drain charge	Qgd	V <sub>GS</sub> = 10V	-	6	-	

**•P Channel Electronic Characteristics**

Parameter	Symbol	Condition	Min.	Typ	Max.	Unit
Drain-Source Breakdown Voltage	BV <sub>DSS</sub>	V <sub>GS</sub> = 0V, I <sub>D</sub> = -250uA	-40			V
Gate Threshold Voltage	V <sub>GS(TH)</sub>	V <sub>GS</sub> = V <sub>DS</sub> , I <sub>D</sub> = -250uA	-1.2		-2.5	V
Drain-Source Leakage Current	I <sub>DSS</sub>	V <sub>DS</sub> = -40V, V <sub>GS</sub> = 0V			-1.0	uA
Gate- Source Leakage Current	I <sub>GSS</sub>	V <sub>GS</sub> = ±20V, V <sub>DS</sub> = 0V			±100	nA
Static Drain-source On Resistance	R <sub>DS(ON)</sub>	V <sub>GS</sub> = -10V, I <sub>D</sub> = -4A		39	50	mΩ
		V <sub>GS</sub> = -4.5V, I <sub>D</sub> = -3A		61	78	mΩ
Forward Transconductance	g <sub>FS</sub>	V <sub>DS</sub> = -10V, I <sub>D</sub> = -4A			1.2	s

**•Electronic Characteristics**

Parameter	Symbol	Condition	Min.	Typ	Max.	Unit
Input capacitance	Ciss	f = 1MHz	-	838	-	pF
Output capacitance	Coss		-	94	-	
Reverse transfer capacitance	Crss		-	70	-	

**•Gate Charge characteristics(T<sub>a</sub> = 25°C)**

Parameter	Symbol	Condition	Min.	Typ	Max.	Unit
Total gate charge	Qg	V <sub>DD</sub> = -25V	-	15.3	-	nC
Gate - Source charge	Qgs	I <sub>D</sub> = -8A	-	2.3	-	
Gate - Drain charge	Qgd	V <sub>GS</sub> = -10V	-	3.6	-	

•N Channel characteristics curve

Fig.1 Power Dissipation Derating Curve

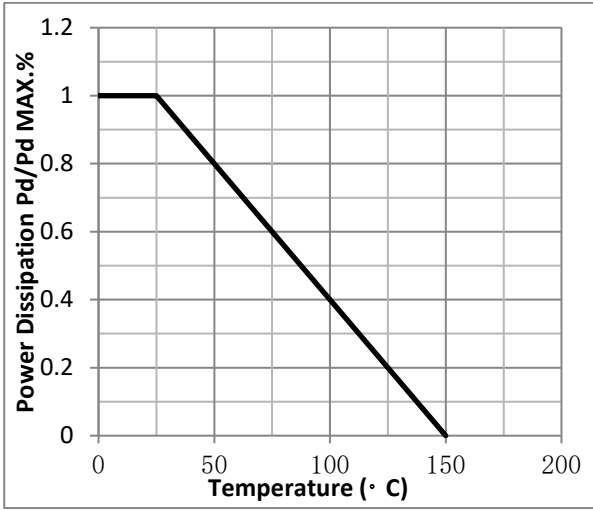

Fig.2 Typical output Characteristics

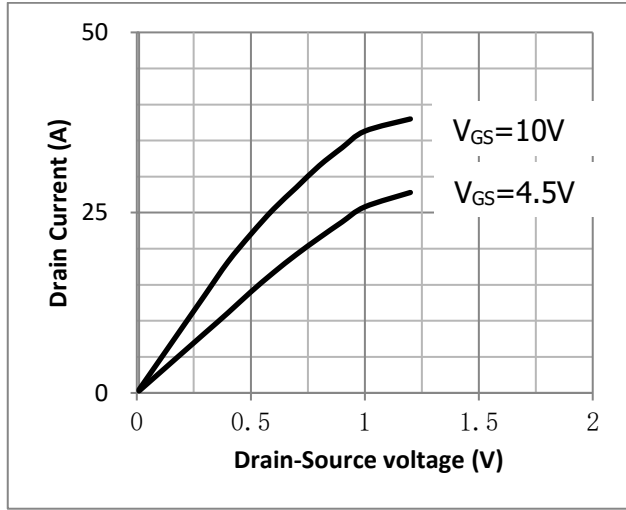

Fig.3 Threshold Voltage V.S Junction Temperature

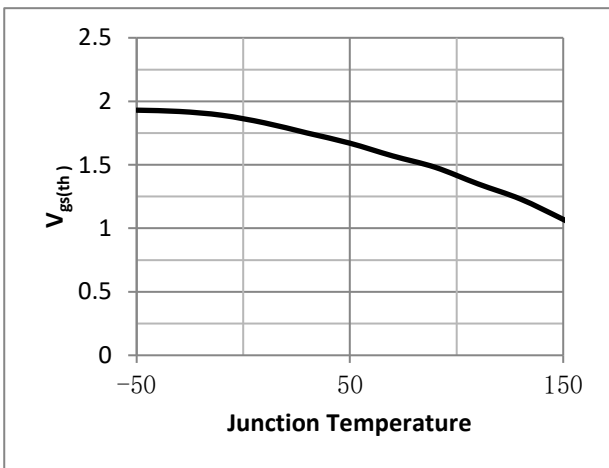

Fig.4 Resistance V.S Drain Current

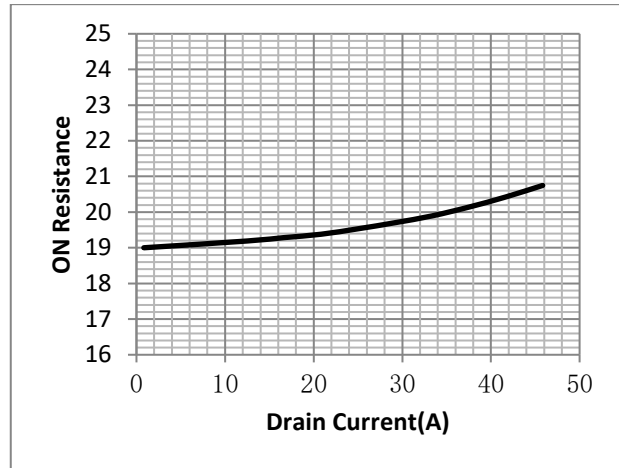

Fig.5 On-Resistance VS Gate Source Voltage

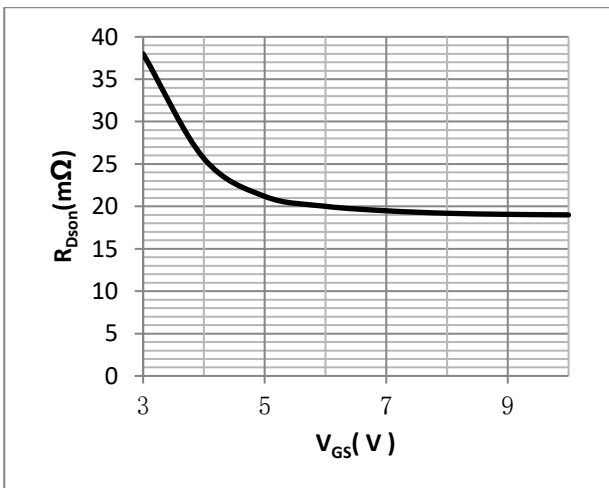
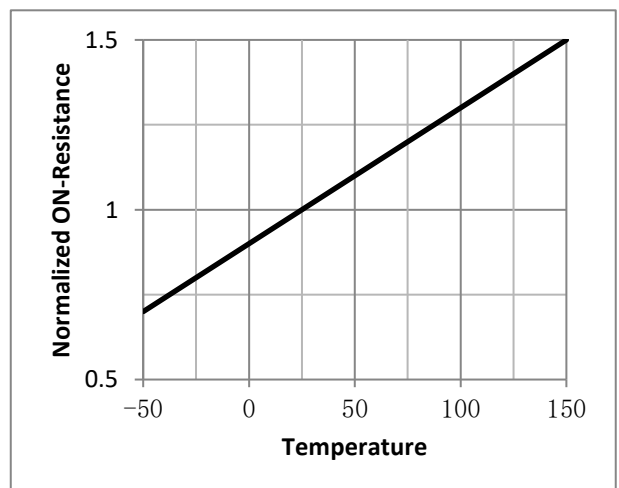

Fig.6 On-Resistance V.S Junction Temperature



•P Channel characteristics curve

Fig.1 Power Dissipation Derating Curve

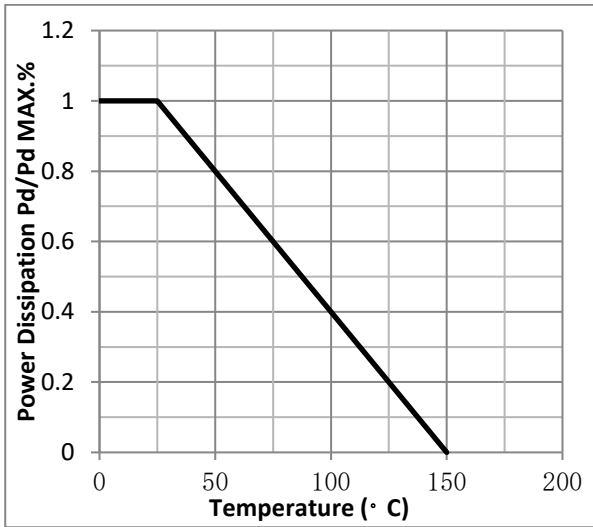

Fig.2 Typical output Characteristics

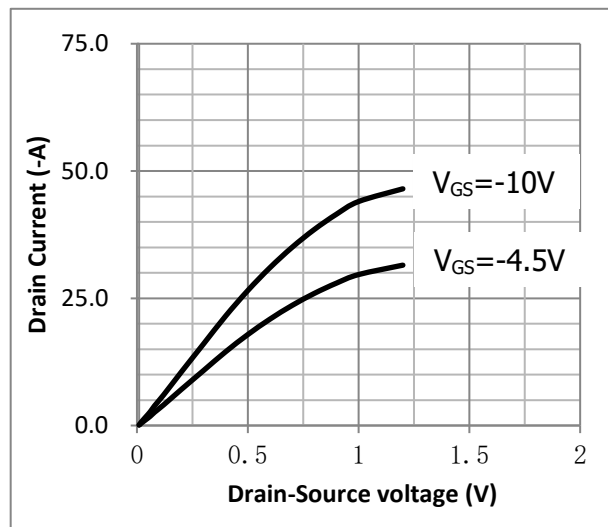

Fig.3 Threshold Voltage V.S Junction Temperature

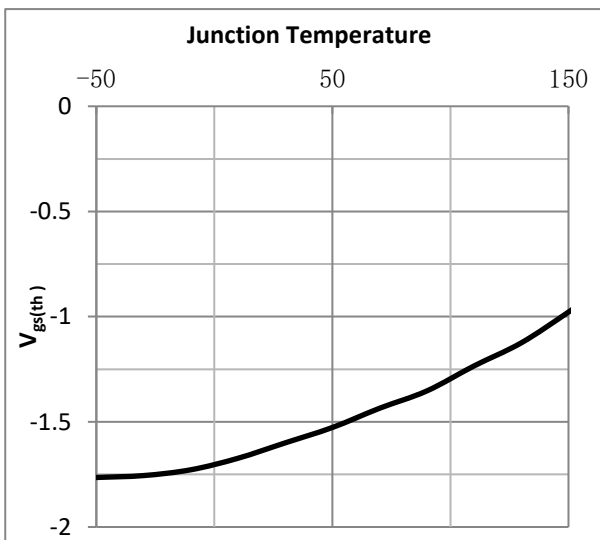

Fig.4 Resistance V.S Drain Current

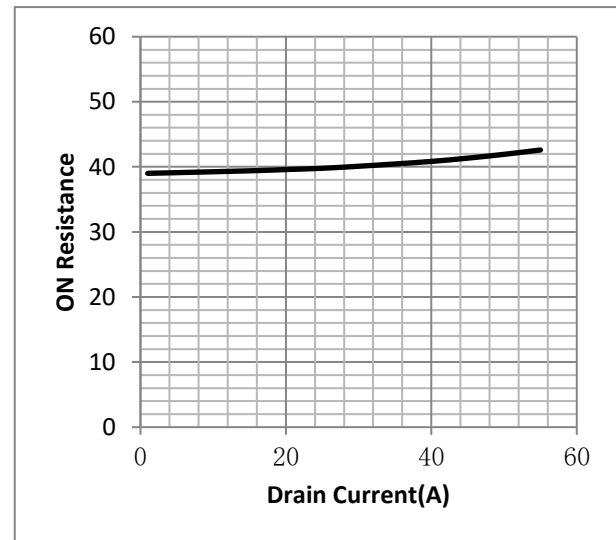

Fig.5 On-Resistance VS Gate Source Voltage

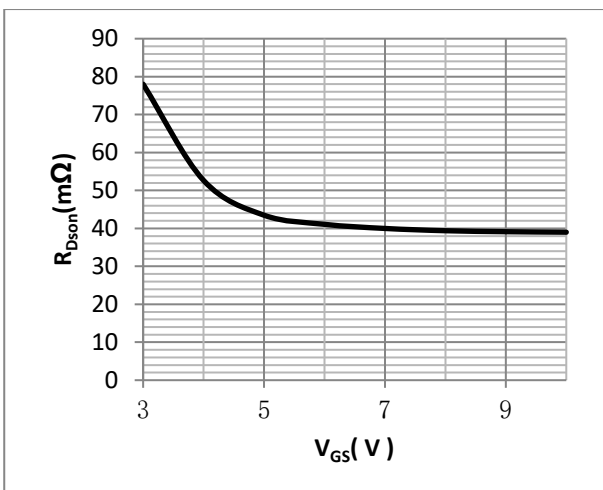
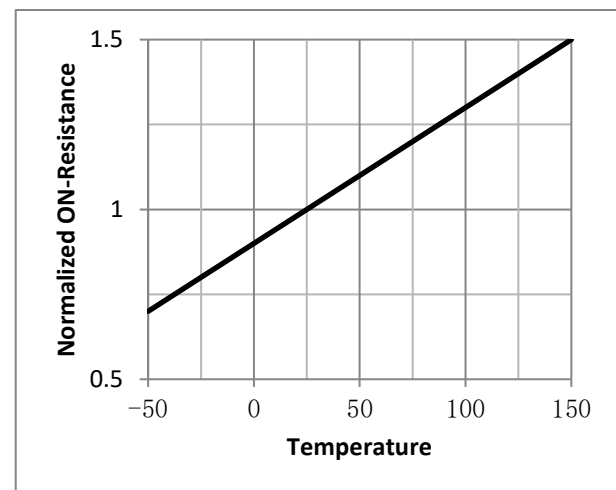

Fig.6 On-Resistance V.S Junction Temperature



•Test Circuit

Fig.1 Switching Time Measurement Circuit

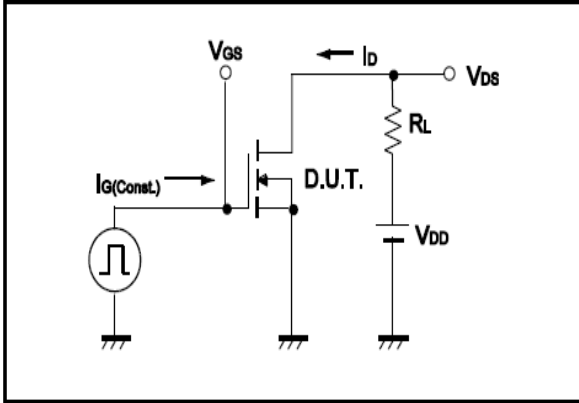

Fig.2 Gate Charge Waveform

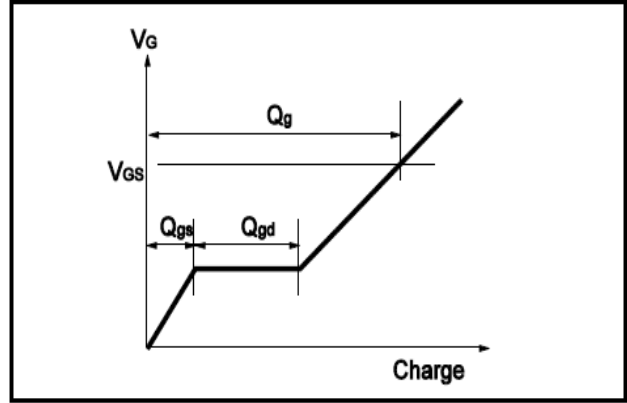

Fig.3 Switching Time Measurement Circuit

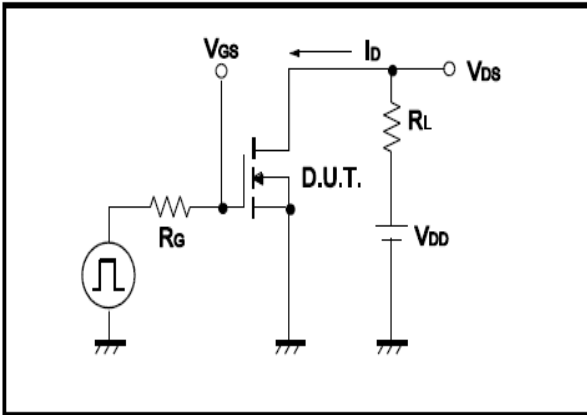

Fig.4 Gate Charge Waveform

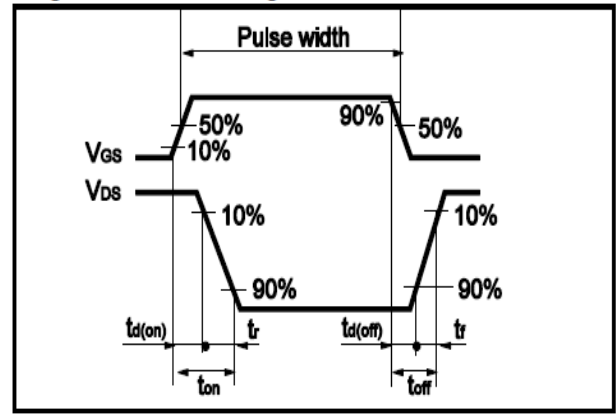

Fig.5 Avalanche Measurement Circuit

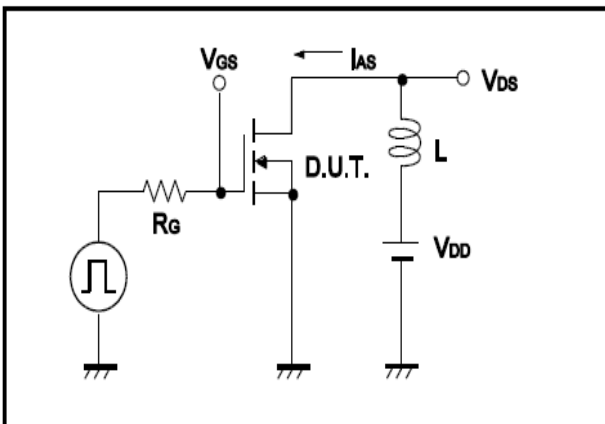
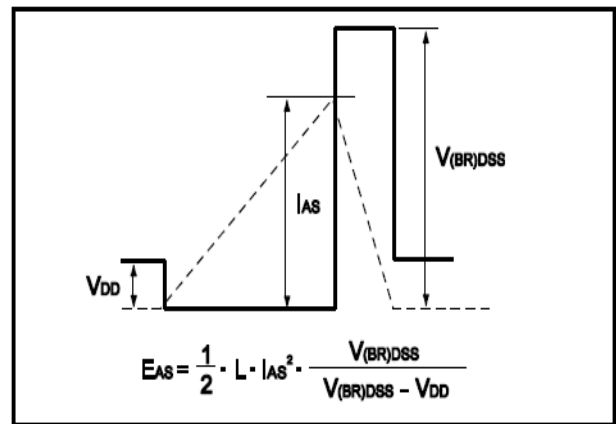

Fig.6 Avalanche Waveform





●Dimensions(TO-252-4)

Unit: mm

