

• General Description

The ZM048N03D combines advanced trench MOSFET technology with a low resistance package to provide extremely low $R_{DS(ON)}$. This device is ideal for load switch and battery protection applications.

• Features

- Advance high cell density Trench technology
- Low $R_{DS(ON)}$ to minimize conductive loss
- Low Gate Charge for fast switching
- Low Thermal resistance

• Application

- MB/VGA Vcore
- SMPS 2nd Synchronous Rectifier
- POL application
- BLDC Motor driver

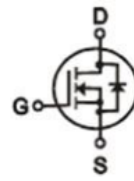
• Product Summary

$V_{DS} = 30V$

$R_{DS(ON)} = 4.8m\Omega$

$I_D = 75A$

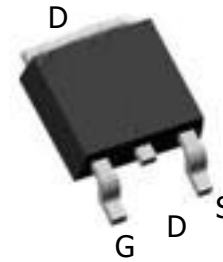
• Ordering Information:

| | |
|---------------------------|-----------|
| Part NO. | ZM048N03D |
| Marking | ZM048N03 |
| Packing Information | REEL TAPE |
| Basic ordering unit (pcs) | 2500 |

• Absolute Maximum Ratings ($T_c = 25^\circ C$)

| Parameter | Symbol | Rating | Unit |
|-----------------------------------|------------------------|------------|------------|
| Drain-Source Voltage | V_{DS} | 30 | V |
| Gate-Source Voltage | V_{GS} | ± 20 | V |
| Continuous Drain Current | $I_D @ TC=25^\circ C$ | 75 | A |
| | $I_D @ TC=75^\circ C$ | 57 | A |
| | $I_D @ TC=100^\circ C$ | 47 | A |
| Pulsed Drain Current ^① | I_{DM} | 180 | A |
| Total Power Dissipation | $P_D @ TC=25^\circ C$ | 60 | W |
| Total Power Dissipation | $P_D @ TA=25^\circ C$ | 2.0 | W |
| Operating Junction Temperature | T_J | -55 to 150 | $^\circ C$ |
| Storage Temperature | T_{STG} | -55 to 150 | $^\circ C$ |
| Single Pulse Avalanche Energy | E_{AS} | 200 | mJ |

•Thermal resistance

| Parameter | Symbol | Min. | Typ. | Max. | Unit |
|--|------------|------|------|------|---------------|
| Thermal resistance, junction - case | R_{thJC} | - | - | 2.1 | $^{\circ}C/W$ |
| Thermal resistance, junction - ambient | R_{thJA} | - | - | 62.5 | $^{\circ}C/W$ |
| Soldering temperature, wavesoldering for 10s | T_{sold} | - | - | 265 | $^{\circ}C$ |

•Electronic Characteristics

| Parameter | Symbol | Condition | Min. | Typ | Max. | Unit |
|-----------------------------------|--------------|-------------------------------|------|-----|-----------|------------|
| Drain-Source Breakdown Voltage | BV_{DSS} | $V_{GS}=0V, I_D=250\mu A$ | 30 | | | V |
| Gate Threshold Voltage | $V_{GS(TH)}$ | $V_{GS}=V_{DS}, I_D=250\mu A$ | 1.2 | | 2.5 | V |
| Drain-Source Leakage Current | I_{DSS} | $V_{DS}=30V, V_{GS}=0V$ | | | 1.0 | μA |
| Gate- Source Leakage Current | I_{GSS} | $V_{GS}=\pm 20V, V_{DS}=0V$ | | | ± 100 | nA |
| Static Drain-source On Resistance | $R_{DS(ON)}$ | $V_{GS}=10V, I_D=20A$ | | 4.8 | 6.2 | m Ω |
| | | $V_{GS}=4.5V, I_D=10A$ | | 6.8 | 9.0 | m Ω |
| Forward Transconductance | g_{FS} | $V_{DS}=25V, I_D=10A$ | | 12 | | S |
| Source-drain voltage | VSD | $I_S=20A$ | | | 1.28 | V |

•Electronic Characteristics

| Parameter | Symbol | Condition | Min. | Typ | Max. | Unit |
|------------------------------|-----------|-----------|------|------|------|------|
| Input capacitance | C_{iss} | f = 1MHz | - | 1500 | - | pF |
| Output capacitance | C_{oss} | | - | 280 | - | |
| Reverse transfer capacitance | C_{rss} | | - | 140 | - | |

•Gate Charge characteristics($T_a = 25^{\circ}C$)

| Parameter | Symbol | Condition | Min. | Typ | Max. | Unit |
|----------------------|-------------|--|------|-----|------|----------|
| Gate Resistance | R_g | f = 1MHz | | 1.7 | | Ω |
| Total gate charge | Q_g | $V_{DD}=25V$ $I_D=5A$ $V_{GS}=10V$ | - | 16 | - | nC |
| Gate - Source charge | Q_{gs} | | - | 5 | - | |
| Gate - Drain charge | Q_{gd} | | - | 8 | - | |
| Turn-ON Delay time | $t_{D(on)}$ | $V_{GS}=10V, V_{DS}=15V$ | | 4.8 | | ns |
| Turn-ON Rise time | t_r | $R_G=3.3\Omega, I_D=15A$ | | 13 | | ns |

| | | | | |
|---------------------|--------------|--|-----|----|
| Turn-Off Delay time | $t_{D(off)}$ | | 28 | ns |
| Turn-Off Fall time | t_f | | 8.3 | ns |

Note: ① Pulse Test : Pulse width $\leq 300\mu s$, Duty cycle $\leq 2\%$;

Fig.1 Power Dissipation

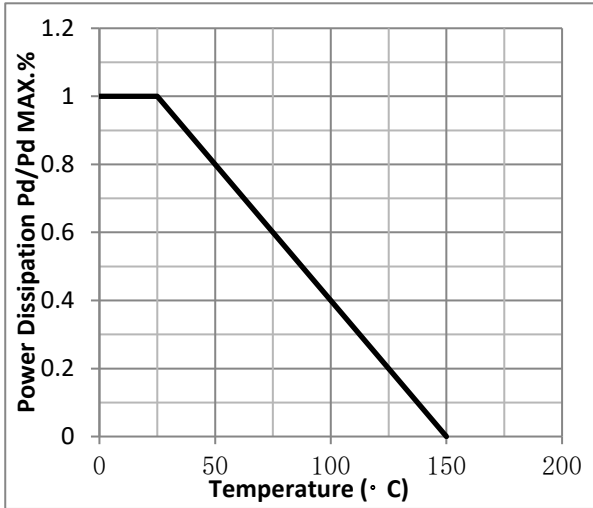

Fig.2 Typical output Characteristics

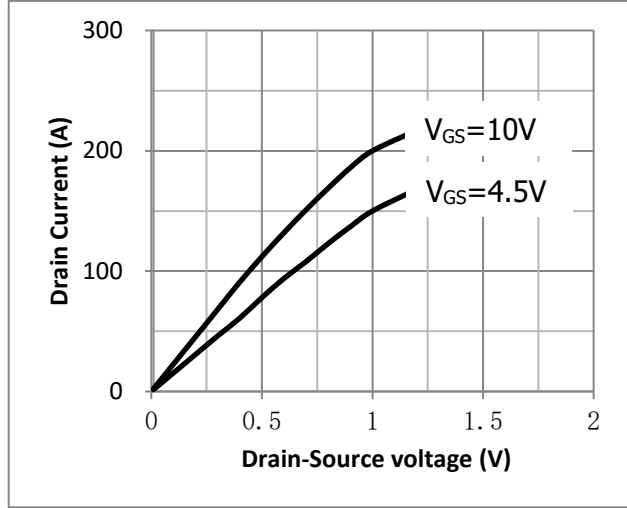

Fig.3 Threshold Voltage V.S Junction Temperature

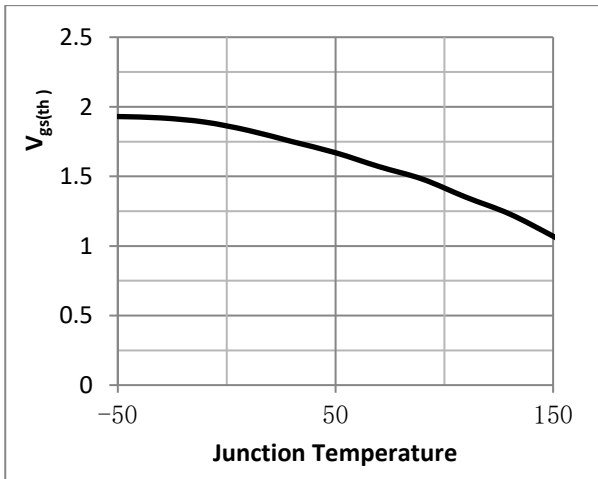

Fig.4 Resistance V.S Drain Current

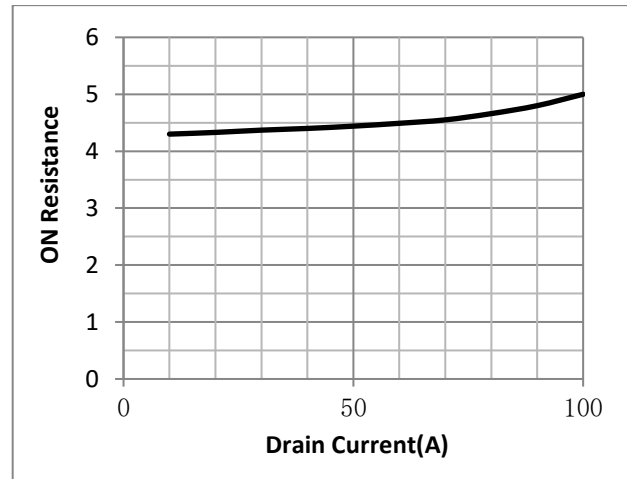

Fig.5 On-Resistance VS Gate Source Voltage

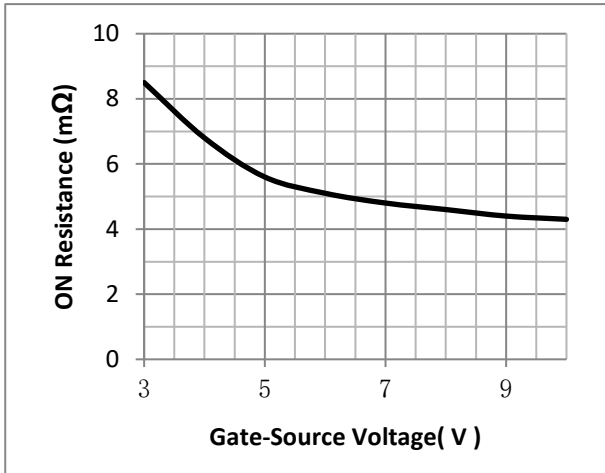

Fig.6 On-Resistance V.S Junction Temperature

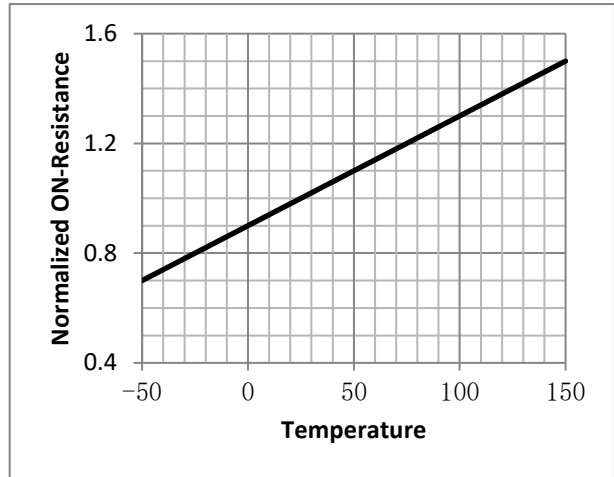

Fig.7 Switching Time Measurement Circuit

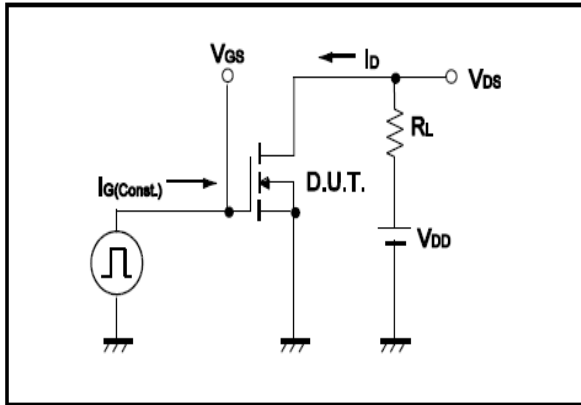

Fig.8 Gate Charge Waveform

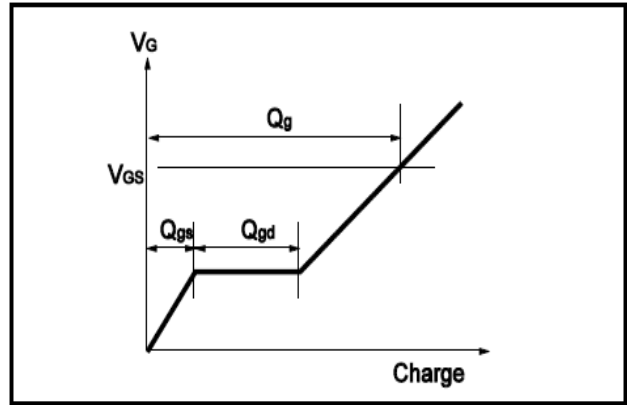

Fig.9 Switching Time Measurement Circuit

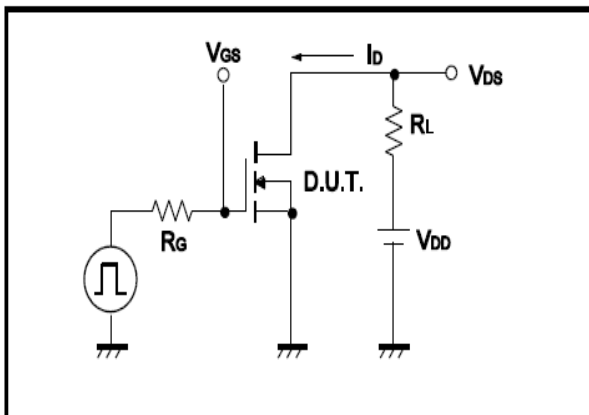

Fig.10 Gate Charge Waveform

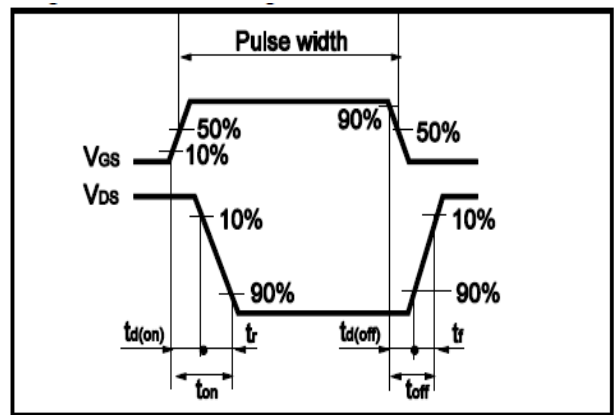

Fig.11 Avalanche Measurement Circuit

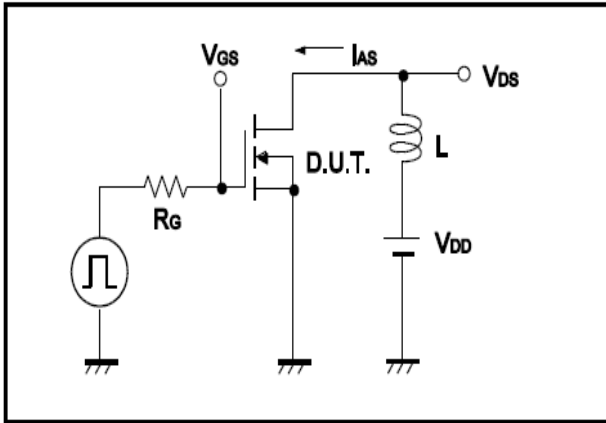
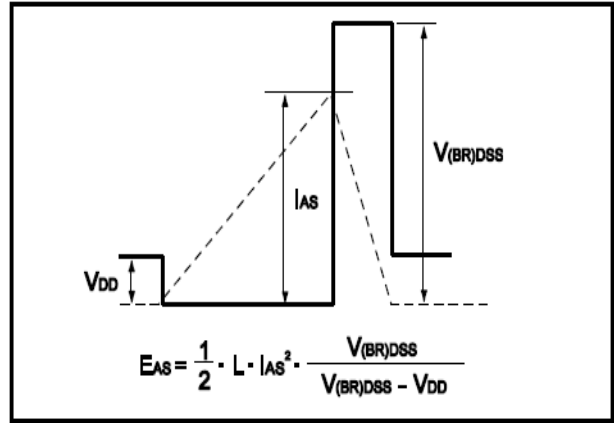

Fig.12 Avalanche Waveform



•Dimensions (TO-252)

Unit: mm

| SYMBOL | min | max | SYMBOL | min | max |
|--------|------|-------|--------|------|------|
| A | 2.10 | 2.50 | B | 0.85 | 1.25 |
| b | 0.50 | 0.80 | b1 | 0.50 | 0.90 |
| b2 | 0.45 | 0.70 | C | 0.45 | 0.70 |
| D | 6.30 | 6.75 | D1 | 5.10 | 5.50 |
| E | 5.30 | 6.30 | e1 | 2.25 | 2.35 |
| L1 | 9.20 | 10.60 | e2 | 4.45 | 4.75 |
| L2 | 0.90 | 1.75 | L3 | 0.60 | 1.10 |
| K | 0.00 | 0.23 | | | |

