

### • General Description

The ZM280N06L combines advanced trench MOSFET technology with a low resistance package to provide extremely low  $R_{DS(ON)}$ . This device is ideal for load switch and battery protection applications.

### • Features

- Advance high cell density Trench technology
- Low  $R_{DS(ON)}$  to minimize conductive loss
- Low Gate Charge for fast switching
- Low Thermal resistance

### • Application

- MB/VGA Vcore
- SMPS 2<sup>nd</sup> Synchronous Rectifier
- POL application
- BLDC Motor driver

### • Product Summary

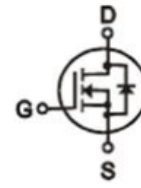

$V_{DS} = 60V$

$R_{DS(ON)} = 28m\Omega$

$I_D = 6A$

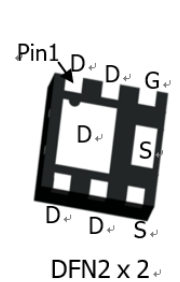

### • Ordering Information:

Part NO.	ZM280N06L
Marking	280N06
Packing Information	REEL TAPE
Basic ordering unit (pcs)	4000

### • Absolute Maximum Ratings ( $T_C = 25^\circ C$ )

Parameter	Symbol	Rating	Unit
Drain-Source Voltage	$V_{DS}$	60	V
Gate-Source Voltage	$V_{GS}$	$\pm 20$	V
Continuous Drain Current	$I_{D@TC=25^\circ C}$	6	A
	$I_{D@TC=75^\circ C}$	4.5	A
	$I_{D@TC=100^\circ C}$	3.7	A
Pulsed Drain Current <sup>①</sup>	$I_{DM}$	18	A
Total Power Dissipation( $TC=25^\circ C$ )	$P_D@TC=25^\circ C$	50	W
Total Power Dissipation( $TA=25^\circ C$ )	$P_D@TA=25^\circ C$	1.25	W
Operating Junction Temperature	$T_J$	-55 to 150	$^\circ C$
Storage Temperature	$T_{STG}$	-55 to 150	$^\circ C$
Single Pulse Avalanche Energy	$E_{AS}$	75	mJ

**•Thermal resistance**

Parameter	Symbol	Min.	Typ.	Max.	Unit
Thermal resistance, junction - case	$R_{thJC}$	-	-	2.4	$^{\circ}C/W$
Thermal resistance, junction - ambient	$R_{thJA}$	-	-	65	$^{\circ}C/W$
Soldering temperature, wavesoldering for 10s	$T_{sold}$	-	-	265	$^{\circ}C$

**•Electronic Characteristics**

Parameter	Symbol	Condition	Min.	Typ	Max.	Unit
Drain-Source Breakdown Voltage	$BV_{DSS}$	$V_{GS}=0V, I_D=250\mu A$	60			V
Gate Threshold Voltage	$V_{GS(TH)}$	$V_{GS}=V_{DS}, I_D=250\mu A$	1.2	1.8	2.5	V
Drain-Source Leakage Current	$I_{DSS}$	$V_{DS}=60V, V_{GS}=0V$			1.0	$\mu A$
Gate- Source Leakage Current	$I_{GSS}$	$V_{GS}=\pm 20V, V_{DS}=0V$			$\pm 100$	nA
Static Drain-source On Resistance	$R_{DS(ON)}$	$V_{GS}=10V, I_D=6A$		28	34	m $\Omega$
		$V_{GS}=4.5V, I_D=4A$		31	40	m $\Omega$
Forward Transconductance	$g_{FS}$	$V_{DS}=25V, I_D=6A$		5		S
Source-drain voltage	$V_{SD}$	$I_S=6A$			1.28	V

**•Electronic Characteristics**

Parameter	Symbol	Condition	Min.	Typ	Max.	Unit
Input capacitance	$C_{iss}$	$V_{GS}=0V, V_{DS}=25V$ $f = 1MHz$	-	1430	-	pF
Output capacitance	$C_{oss}$		-	160	-	
Reverse transfer capacitance	$C_{rss}$		-	115	-	

**•Gate Charge characteristics( $T_a = 25^{\circ}C$ )**

Parameter	Symbol	Condition	Min.	Typ	Max.	Unit
Total gate charge	$Q_g$	$V_{DD} = 25V$ $I_D = 5A$ $V_{GS} = 10V$	-	25	-	nC
Gate - Source charge	$Q_{gs}$		-	4	-	
Gate - Drain charge	$Q_{gd}$		-	9	-	

Note: ① Pulse Test : Pulse width  $\leq 300\mu s$ , Duty cycle  $\leq 2\%$  ;

Fig.1 Maximum Continuous Drain Current

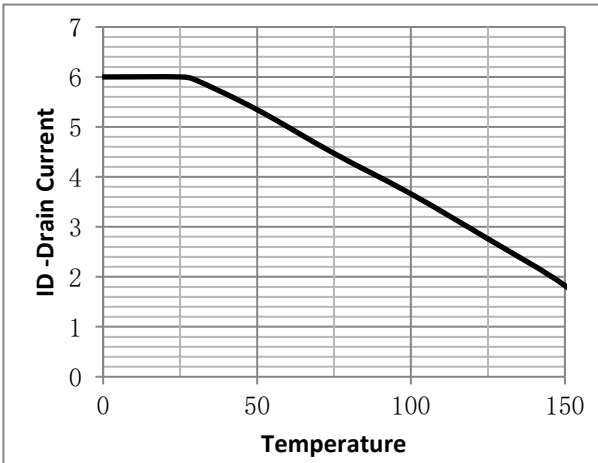

Fig.2 Typical output Characteristics

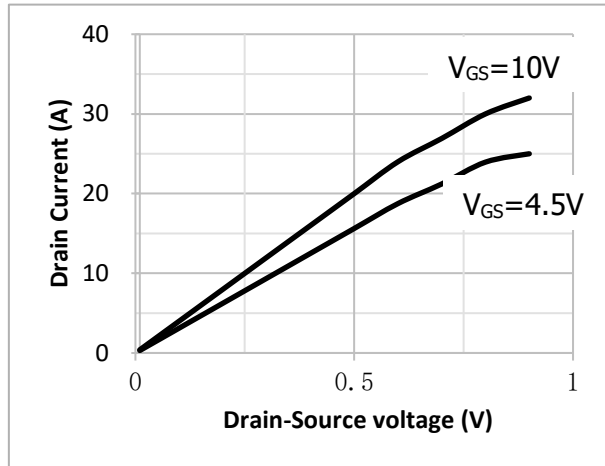

Fig.3 Threshold Voltage V.S Junction Temperature

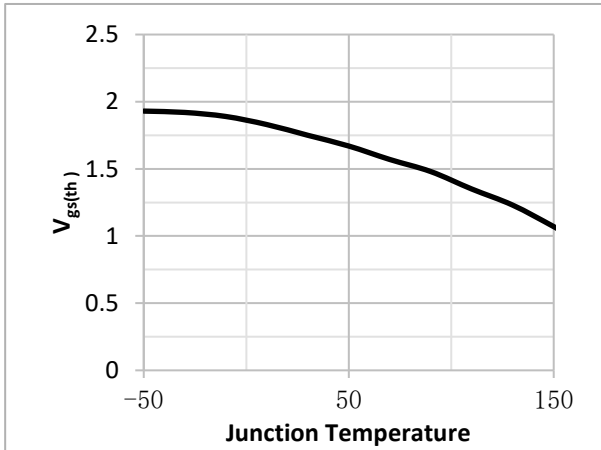

Fig.4 Resistance V.S Drain Current

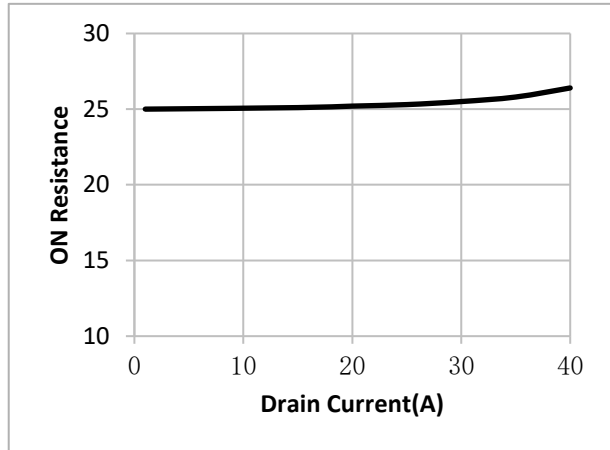

Fig.5 On-Resistance VS Gate Source Voltage

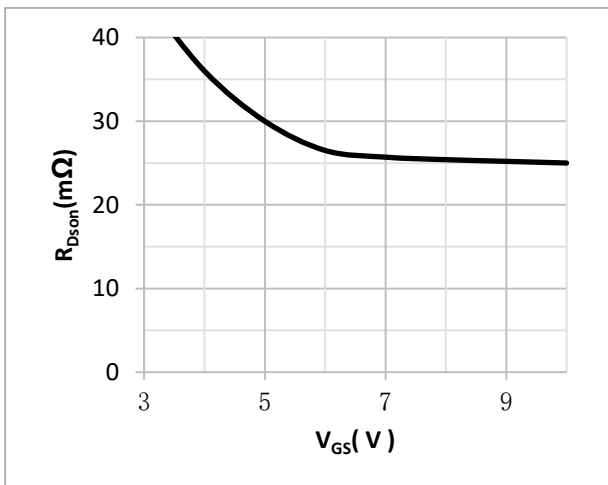

Fig.6 On-Resistance V.S Junction Temperature

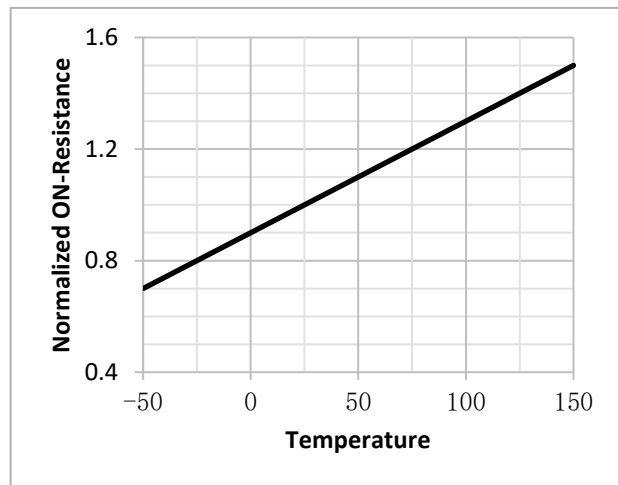

Fig.7 Switching Time Measurement Circuit

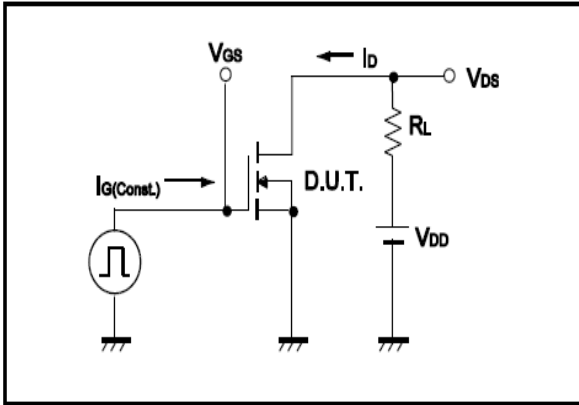

Fig.8 Gate Charge Waveform

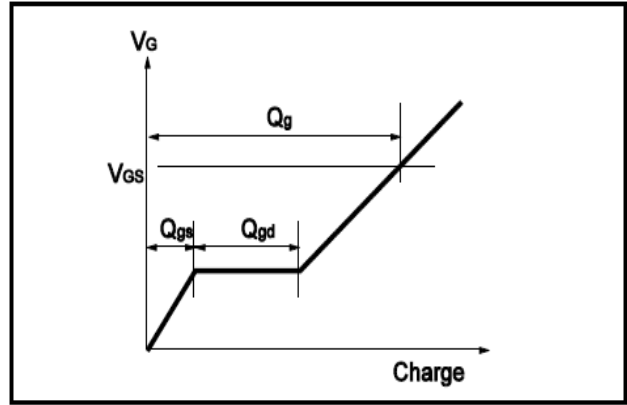

Fig.9 Switching Time Measurement Circuit

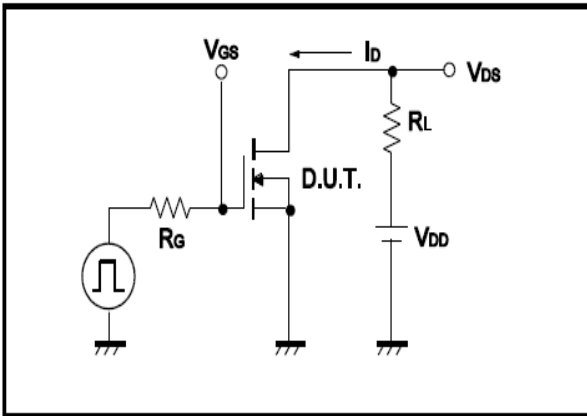

Fig.10 Gate Charge Waveform

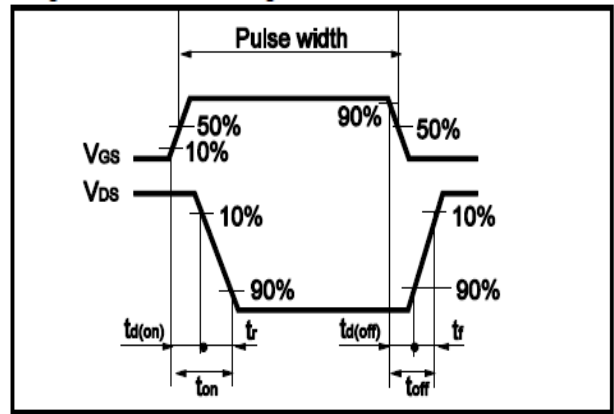

Fig.11 Avalanche Measurement Circuit

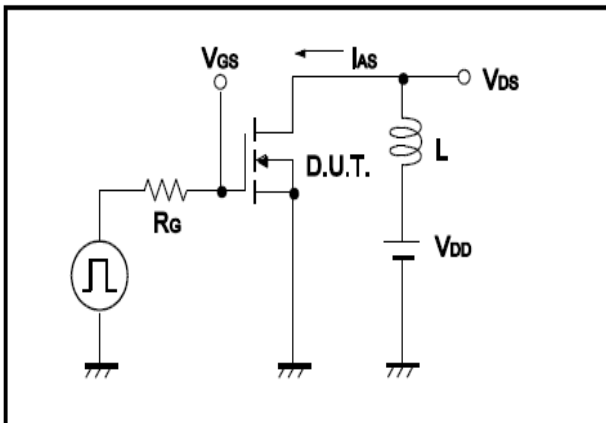
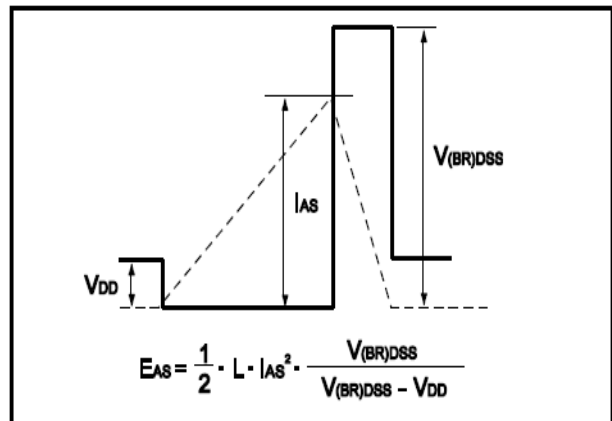

Fig.12 Avalanche Waveform





•Dimensions(DFN2\*2)

Unit: mm

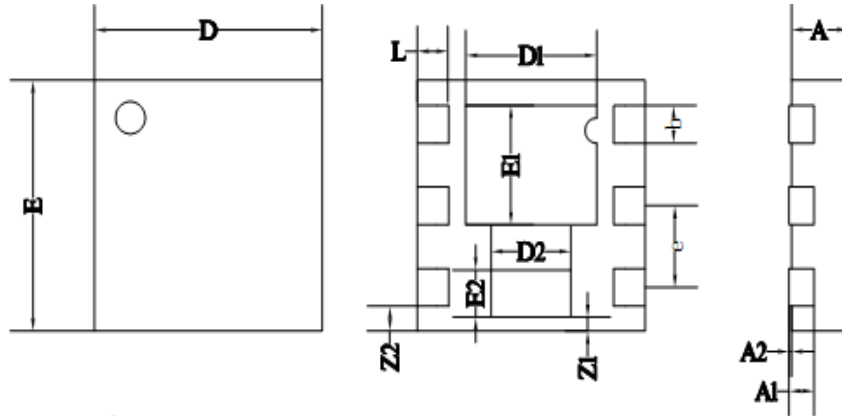

NOTE:  
All dimensions are in mm

	MIN	NOM	MAX
<b>D</b>	1.95	2.00	2.05
<b>E</b>	1.95	2.00	2.05
<b>D1</b>	1.10	1.15	1.20
<b>E1</b>	0.90	0.95	1.00
<b>D2</b>	0.65	0.70	0.75
<b>E2</b>	0.33	0.38	0.43
<b>L</b>	0.225	0.275	0.325
<b>b</b>	0.25	0.30	0.35
<b>e</b>	0.65BSC		
<b>A</b>	0.45	0.50	0.55
<b>A1</b>	0.20REF		
<b>A2</b>	0.00	-	0.05
<b>Z1</b>	0.06	0.11	0.16
<b>Z2</b>	0.15	0.20	0.25